

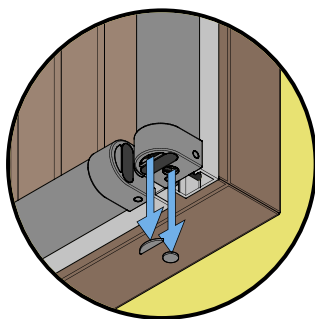

IMPORTANT INFORMATION!

PLEASE READ AND FOLLOW THE INFORMATION BELOW REGARDING THE CORRECT INSTALLATION OF THESE SAFETY EDGES.

DRAINAGE HOLES **MUST** BE MADE PRIOR TO FITTING!



On vertical installations remove the drainage caps from the bottom end cap.

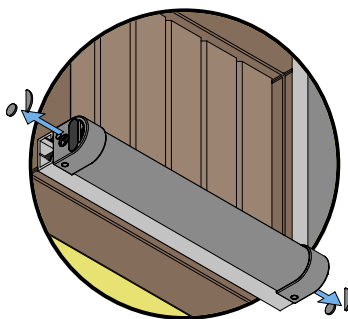

On horizontal installations remove the drainage caps from both endcaps.

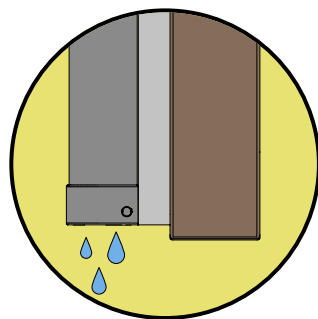

This will allow ingress to escape and prevent water damage to the system.

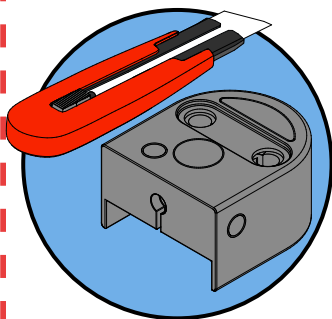

Using a **precise** cutting tool...

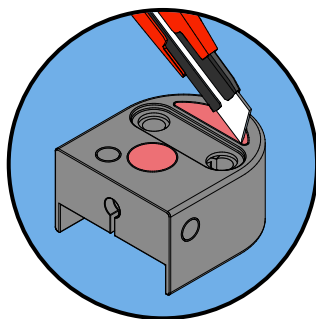

...remove both 'D' & 'O' shaped drainage caps...

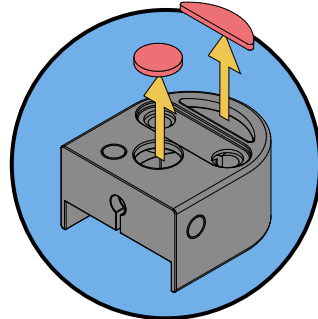

...as shown above.

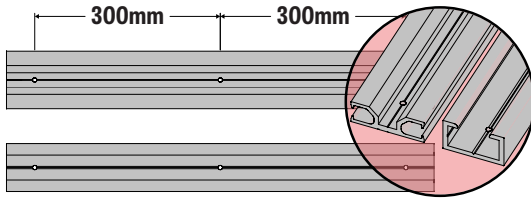

1. Mount the alu carrier and drill holes at points spaced 300-500mm apart minimum.

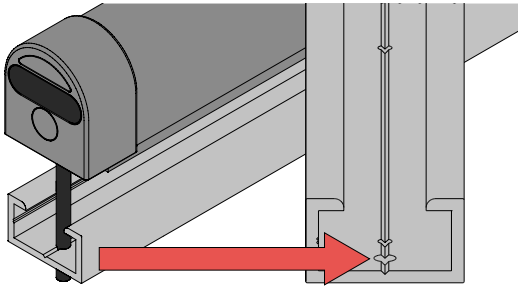

3. Drill additional 8mm hole in the desired location to draw any cables through the alu carrier and frame of gate/door.

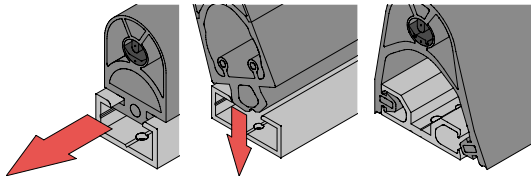

5. Fit the safety edge to the carrier as illustrated (edges with **T foot** slide in) (edges with a **C foot** clip in from above) (edges with a **Clip foot**, clip over either side of the safety edge).

6. !WARNING! do not attempt to pull T foot or C foot edges in to the alu carrier using the attached cables, this can damage the edges assembly and will invalidate any warranty.

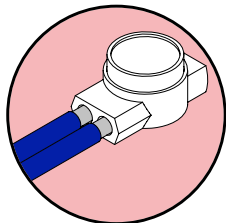

ASO EDGES MUST BE CONNECTED IN SERIES WIRING, NOT PARALLEL

8. When joining cables between safety edges or junction boxes, use weather proof connectors such as gel crimps or properly soldered and heatshrunk connectors rated at IP 65 or above **!WARNING!** Failure to join cables properly will invalidate any warranty of the safety edge.

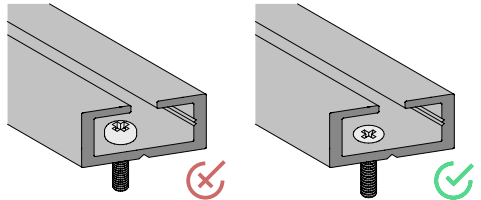

2. Use pan headed or counter sunk screws where possible to prevent snagging of the rubber edge.

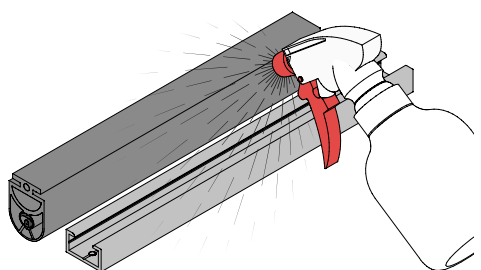

4. Use soapy water spray solution to coat the rubber foot and the alu carrier before attempting to install.

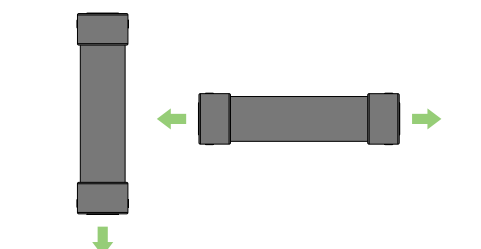
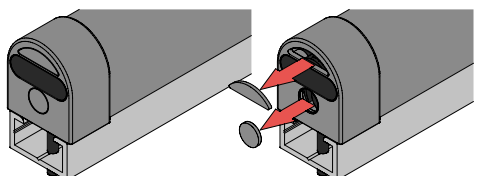

7. Finally ensure that water drains from the end caps have been removed as illustrated (for vertical installations remove only the lower water drain (for horizontal installations remove water drains from both ends of the safety edge) **!WARNING!** failure to remove water drains from the safety edge will invalidate any warranty.



PLEASE NOTE: for **SKL8-8** & **SKL15-10** safety edges there is no water drain to remove from the end caps.